

U3 Fixed product information sheet

Product Specifications

Fits most: 37" - 63" flat panels

Supports up to: 200 lbs (90.7 kg)

Mounting profile: 2.4" (61mm)

Universal & VESA compliant: 100x100 to 400x600

Mounting: Double-stud

UL listed: Yes

Warranty: 5 years

Color: Black and Platinum

Product Benefits

- Universal rails for greater panel compatibility
- Lift n' Lock™ allows you to easily attach your flat panel to the mount
- Sliding lateral on-wall adjustment
- Open architecture provides easy access to in-wall wiring
- Locking system secures panel to mount
- Rail hooks are padded to avoid metal-on-metal contact and reduce vibration
- Installation template for simple and accurate mounting
- Includes complete hardware kit



The U3 Fixed comes with an installation template to ensure a quick, easy and accurate installation



UL LISTED

Series



75/100 FD



QM100 T*

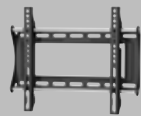

U2 Fixed**

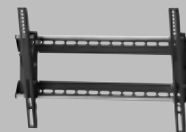

U3 Tilt***



2004 CEDIA Manufacturers' Excellence Award



75/100 CL

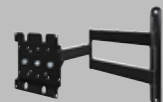

FP-CL



UCL

* also available in small and medium fixed

** also available in large/extra large

*** also available in small and medium

OmniMount, an innovator of A/V mounts and furniture for more than a quarter century, is the choice of professional installers and the brand most recommended by flat panel manufactures. The Classic Series is a full line of fixed, tilt, flip down and cantilever mounting solutions designed with simplicity and reliability in mind. The U3 Fixed is a solid choice for consumers who need a large/extra large fixed mount with universal compatibility.



U3 Fixed technical data sheet



OmniMount, an innovator of A/V mounts and furniture for more than a quarter century, is the choice of professional installers and the brand most recommended by flat panel manufactures. The Classic Series is a full line of fixed, tilt, flip down and cantilever mounting solutions designed with simplicity and reliability in mind. The U3 Fixed is a solid choice for consumers who need a large/extra large fixed mount with universal compatibility.



cUL US LISTED

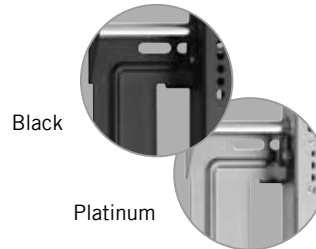

Product Specifications

Fits most: 37" - 63" flat panels

Supports up to: 200 lbs (90.7 kg)

Mounting profile: 2.4" (61mm)

Universal & VESA compliant: 100x100 to 400x600

Mounting: Double-stud

UL listed: Yes

Warranty: 5 years

Color: Black and Platinum

Product Benefits

- Universal rails for greater panel compatibility
- Lift n' Lock™ allows you to easily attach your flat panel to the mount
- Sliding lateral on-wall adjustment
- Open architecture provides easy access to in-wall wiring
- Locking system secures panel to mount
- Rail hooks are padded to avoid metal-on-metal contact and reduce vibration
- Installation template for simple and accurate mounting
- Includes complete hardware kit

	Color	Stock Code	Packaging UPC	MC UPC
Americas	Black	1002079-1	728901014208	NA
International	Black	1002079EU-1	728901017865	NA
Americas	Platinum	1002055-1	728901013652	NA
International	Platinum	1002191-1	728901014062	NA

	Dimensions WxDxH inches (mm)	Wt lbs (kg)
Product Box	11.3 x 32.1 x 4.7 (286x816x119)	19.4 (8.8)
Master Carton	NA	NA

Box Contents	Qty
Wall plate	1
Vertical rail	2
Cable management cover	1
Installation template	1
Complete mount installation hardware kit	1
Complete panel attachment hardware kit	1
Instruction manual	1
Flat panel compatibility chart	1

U3 Fixed line drawing

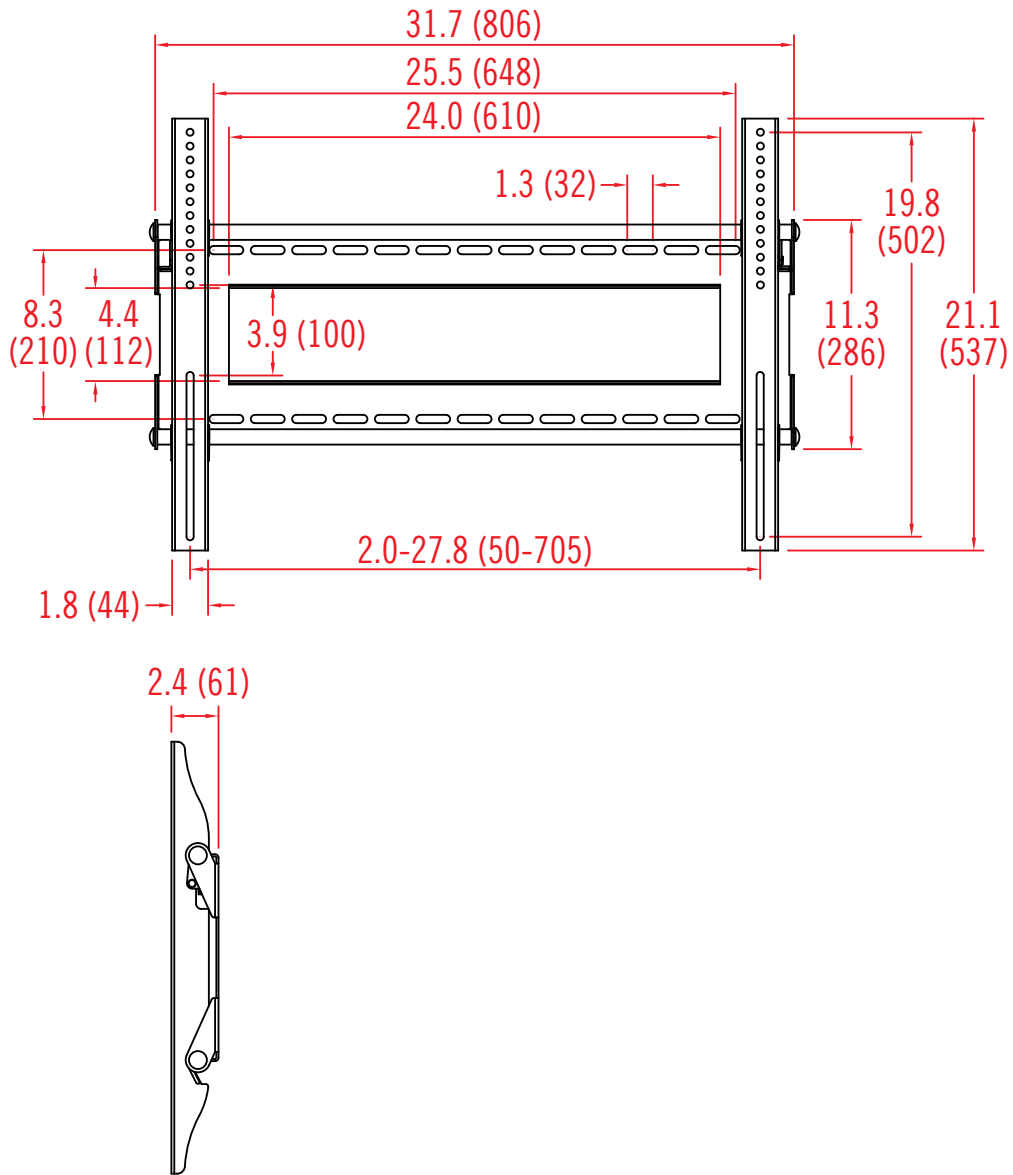

inches (mm)